

A(MG)900 Series Multi-functional Digital Controller

Instruction Manual V1.0

Thanks for purchasing our A(MG)900 Series controllers. This manual mainly describe some instructions on installation and cable setting while using our products. Pls read this through carefully for the full understanding of operating program. Keep this manual at hand for your reference.

1. Precaution for safe use

! Caution

1.Attention! Electrical Hazard!
Do not touch the AC power supply terminal position when the controller is power on, to avoid electric shock.

! Warning

- 1.Please do not use the product in places where explosive or flammable gases may be present.
- 2.Please make sure that the load power supply is within the rating and terminal position is correct before supplying
- 3.Maximum torque of terminal must be within the range such as 8KG.
- 4.Disassembling, modifying and repairing the product is forbidden.
- 5.Please do not use the product in the following conditions:
 - Places where temperature fluctuates dramatically.
 - Places where humidity is high and condensation may occur.
 - Places where oscillation is drastic.
 - Places where there is caustic gases or dust.
 - Places where there is danger of splashing of water, oil or any chemicals.

2. Functions and Performance

Power Supply	AC85~265V, 50/60Hz(DC power is optional)	Display deviation	±0.2%FS
Power Consumption	6VA Max	Master Control Input Type	General input(T/C, PT100, analogy signal)
Control Ways	PID、PD、PI、P	Output	Relay, SSR, 4-20mA
Application Environment Temperature	-10~50℃		
Application Environment Humidity	0-85% RH	Sampling Period	150ms

Specifications

- (1)Signal input: Universal Input
- (2)Adopt the slope value (PV1,OFFSET) to compensate the offset
- (3)Fuzzy was added to avoid overshoot coefficient
- (4) This controller has 2 sets of temperature control output and 1 set of transmit output, which can meet the requirements of various controller.
- (5)This controller can set the value of PV,SV and MV to the positive or negative sides.
- (6) This controller has parameter running specifications RUN to choose the working or stop status.
- (7) Output soft start function
- (8) Dehumidification function
- (9) (A)MG900 controller has the following features:
 - ① The controller is pre-installed with the program setting methods of 60 steps of multi-step and multi-group freely combination temperature, which has multiple start methods, multiple group running ways(skipping groups is possible) and the manually clock changing privilege. It can be used as a constant controller when the STA value is set to zero.
 - ② To end the program control, there are two options on the menu

END
0-1
 - ③Upper monitor can program many prospects for the the controller, such as programming the process curve, initiating the program control, ending, pause, manual or automatic control, etc.

3. Panel cutting Size and Dimension

●Panel cutting size

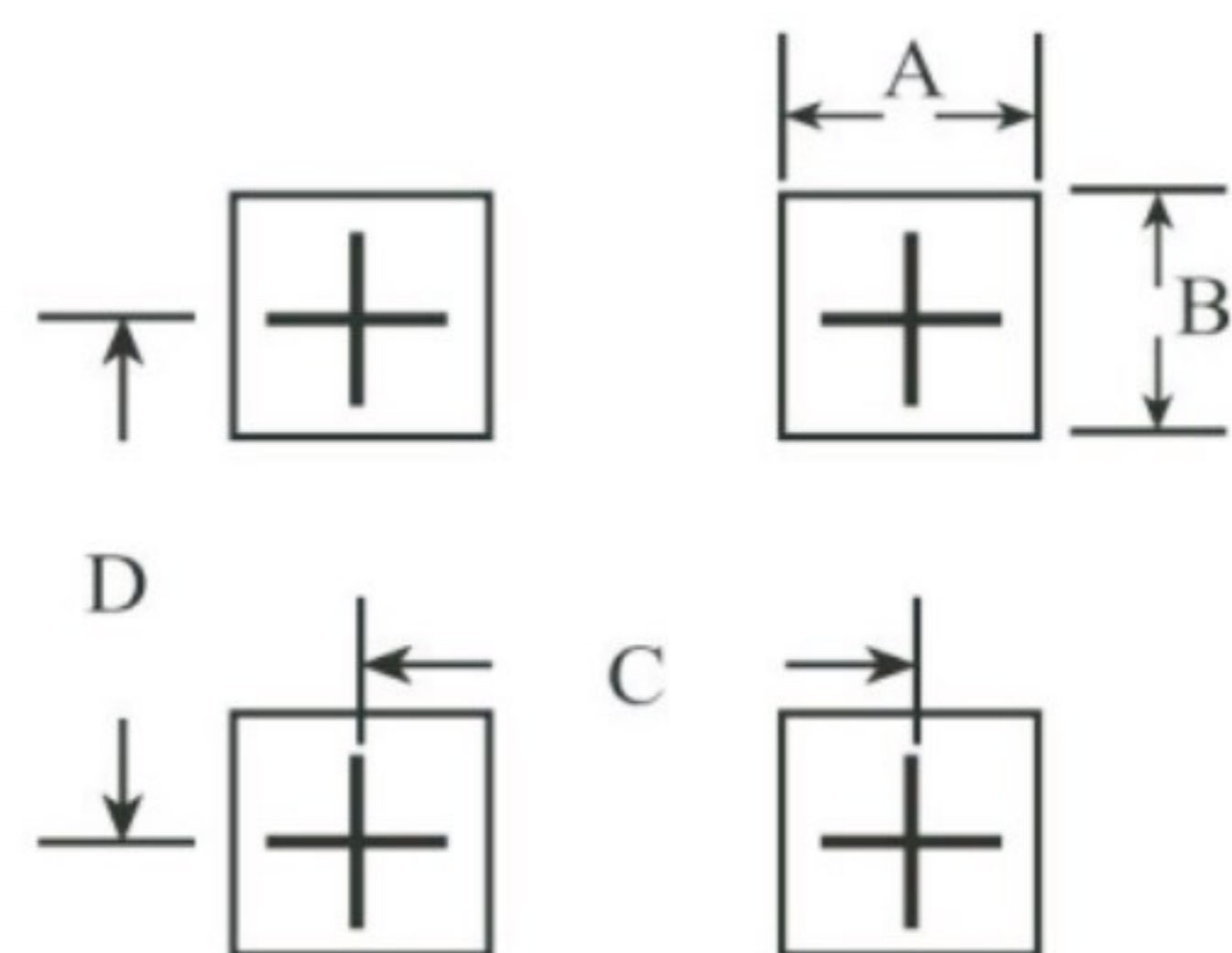

●Dimension

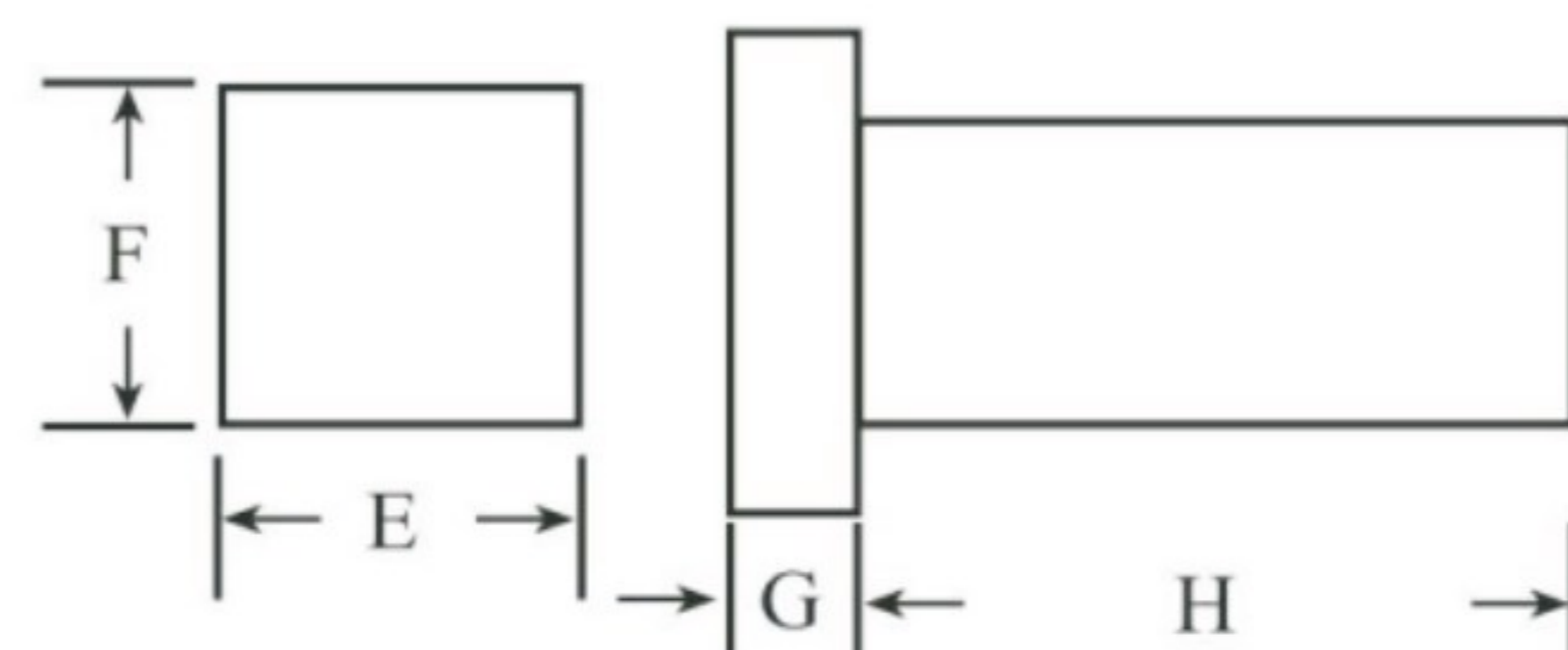

Size Model	A	B	C	D	E	F	G	H
MG904	45+0.6	45+0.6	≥60	≥60	48	48	4.1	71
MG908	45+0.6	92+0.8	≥60	≥130	48	96	4.1	71
MG909	92+0.8	92+0.8	≥130	≥130	96	96	4.1	71

- E. In LEVEL0 process, press SET key for a few times, to enter the AT setting layer, and then press ◀ and ▲ keys to enter "1", so that AT can be initiated. (Make sure the parameter running status is set to RUN=1)
- F. When = "0", the controller is used as fixed value controller. When = "1", "2", the controller is used program controller.
- G. When the controller is switched on with current and =0, there won't be any output.

2. Special function

1) Mode switching of Auto/Manual Control

Press A/M key and the mode indicator will be on, then enter the manual mode. The SV monitor value is the output percentage, and the PV monitor value is the the measurement value. Use ◀, ▲ and ▲ ▼ keys to manually change the output percentage. Then press A/M key and when the indicator is off, the parameter switched to the auto mode. (Notice: Parameter can enter to the Auto/Manual mode under any conditions.)

2) Manually revise the PID value

Under LEVEL0, press SET and ◀ key to enter LEVEL2. Press SET key to choose and set the P, I, D value

3) Room temperature display amend

4) Specification Swift Searching

Press SET key to go forth to select the specifications, while press ▼ to go back and select the specifications.

5) Swift Searching Specifications Function of pre-set or amend group

This controller contains 60 groups at MAX, so that key can only move to one group to another. In order to make the program in a faster way, the following methods are adopted:

Press SET key to enter the program zone menu. When pressing the ▲ or ▼ key, each time you can add or reduce 10 to the COX(C1X...CNX), (C60, C30, C10). When entering the pre-set 10 groups, use the key to set the value one by one. Whether the main interface is under program zone, the 1st or 2nd process or not, you can return to the mode when pressing the ▲ and ▼ at the same time.

4. Description of front panel



Symbol	Name	Function description
SET	Loop/confirmation key	Press to affirm parameter value for its settings
A/M	Auto/Manual	1. toggle switch between manual and auto control .
←	Shifting Key	Moving set point digit(thousand, hundred, ten, digit)
▲	UP Key	Increase the setting
▼	Down key	1.Decrease the setting 2.For the back button function (In the parameter flow)
PV	Measurement value(PV)/parameter name display	1.display measurement value PV 2.display parameter name when parameter setting 3.display type of error for error display
SV	Settings(SV)/parameter display	1.display settings SV 2.display parameter settings for parameter setup
MV	Control output value(MV)	Control output current output value
COM	COM indicator	When the lights is flashing ,it indicates that the communication is running .

Symbol	Name	Function description
↗	Rampup indicator	When lit Rampup light , it indicates that the program to rampup .
→	Soak indicator	when lit Soak light ,it indicates that the program to SOAK.
↘	Ramp down indicator	when lit ramp down light , it indicates that the program to rampdown .
AL1	Alarm indicator	When the meter triggers an alarm 1,lit the AL1
AL2	Alarm indicator	When the meter triggers an alarm 2,lit the AL2
OUT1	Output1 indicator	when lit the Output 1 ,it indicates output1 running.
OUT2	Output 2 indicator	when lit the Output2 , it indicates output 2 running.
MAN	Manual indicator	When Manual indicator on,it indicates manual control running.
AT	AT indicator	When lit AT indicator,it indicates Auto-tuning.
RUN	Run indicator	When lit Run indicator,it indicates the meter running.

5. Signal Input / Alarm Mode Selection table

Type	Display code	Measurement Range
K	<i>K</i>	-270-1370°C/0-2498°F
J	<i>J</i>	-210-1200°C/0-2192°F
R	<i>r</i>	-50-1760°C/0-3216°F
S	<i>S</i>	-50-1760°C/0-3216°F
B	<i>b</i>	0-1820°C/0-3308°F
E	<i>E</i>	-200-1000°C/0-1832°F
T	<i>t</i>	-270-600.0°C/0-1112°F
PT100	<i>Pt</i>	-199.9-600.0°C/-327.8-1112°F
Cu50	<i>Cu</i>	0-150.0°C/0-302.0°F
LN	<i>Ln</i>	Linear analog signal 4-20MA 0-1V, 0-50MV, 0-5V
N	<i>n</i>	-270-1300.0°C/0-2372.0°F
W1	<i>W1</i>	0-2000.0°C/0-3632.0°F
W2	<i>W2</i>	0-2320.0°C/0-4208.0°F

Code	AL1/AL2 Mode Description
0	Deviation upper alarm
1	Deviation lower alarm
2	Absolute value upper alarm
3	Absolute value lower alarm
4	Zone internal alarm
5	Zone external alarm
6	(No alarm at the first time)
7	(No alarm at the first time)
8	Thermo couple breaking alarm
9	Zone internal alarm(No alarm at the first time)
10	Constant temperature at fixed time alarm
11	Program segmentending alarm
12	Program running alarm
13	Program ending alarm
14	PV value zone internal alarm
15	PV value zone external alarm

Alarm mode reference chart

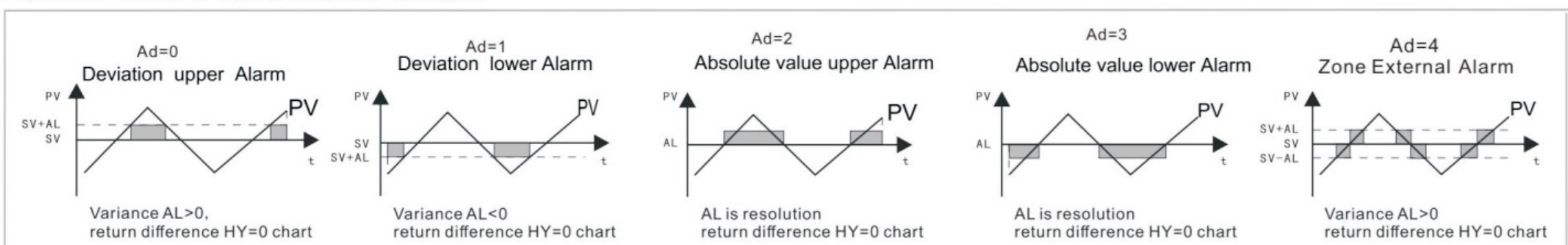

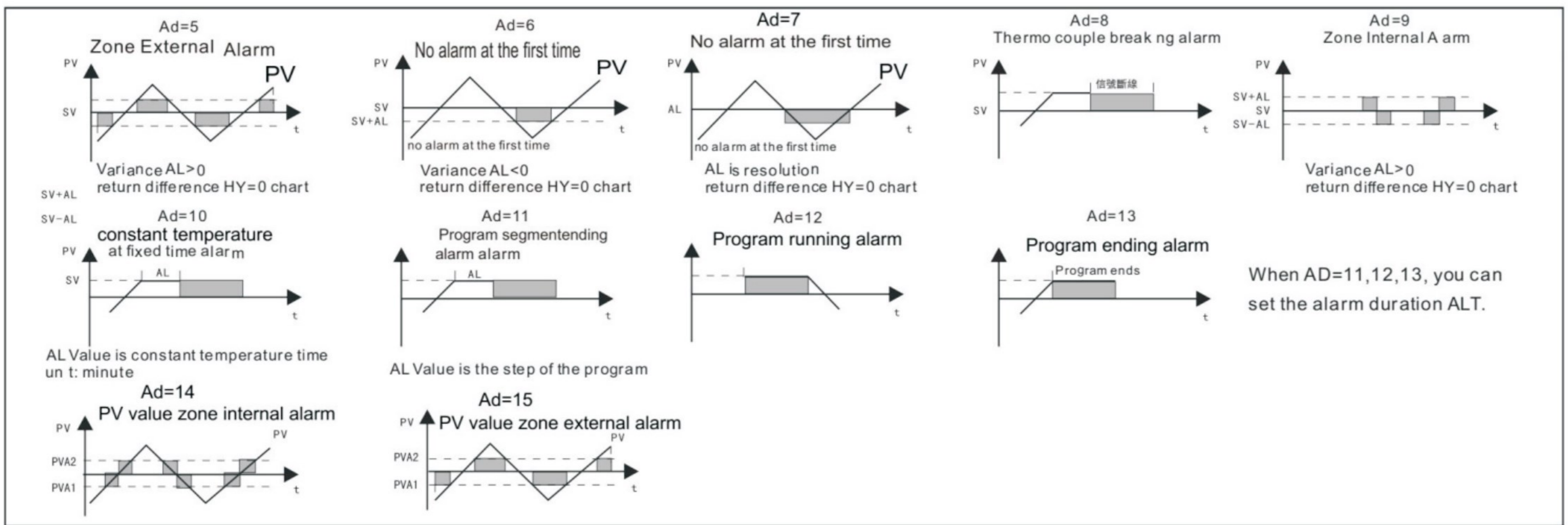

6. Trouble Shooting

Screen Display	Malfunctions	Measures
UUU!	1.First set sensor is disconnected,or the polarity is opposite or out of the range. 2.First set input signal is lower than USP.	1.Please check whether the signal input errors 2.Please check if the input is reasonable.
nnni	First set input signal is lower than USP	Please check if the input range is reasonable
CJCE	Cold junction compensation failure	Please check whether the temperature compensation diode is junction
UUUU	Thermal couple circuit is disconnected	Please check if the thermal couple or the compensation conductor is disconnected

7. Wiring diagram

1、MG909 and MG908

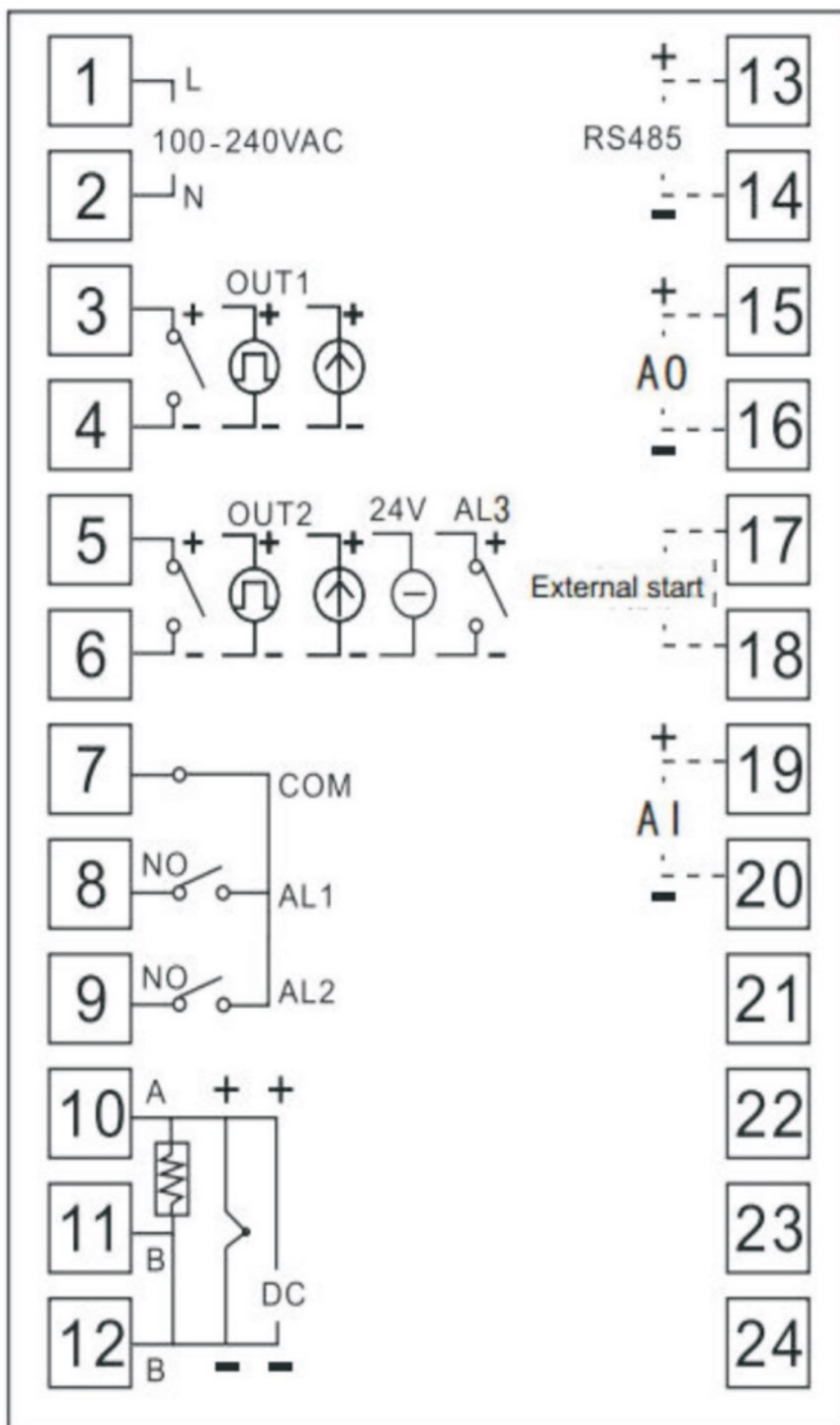

2、MG904

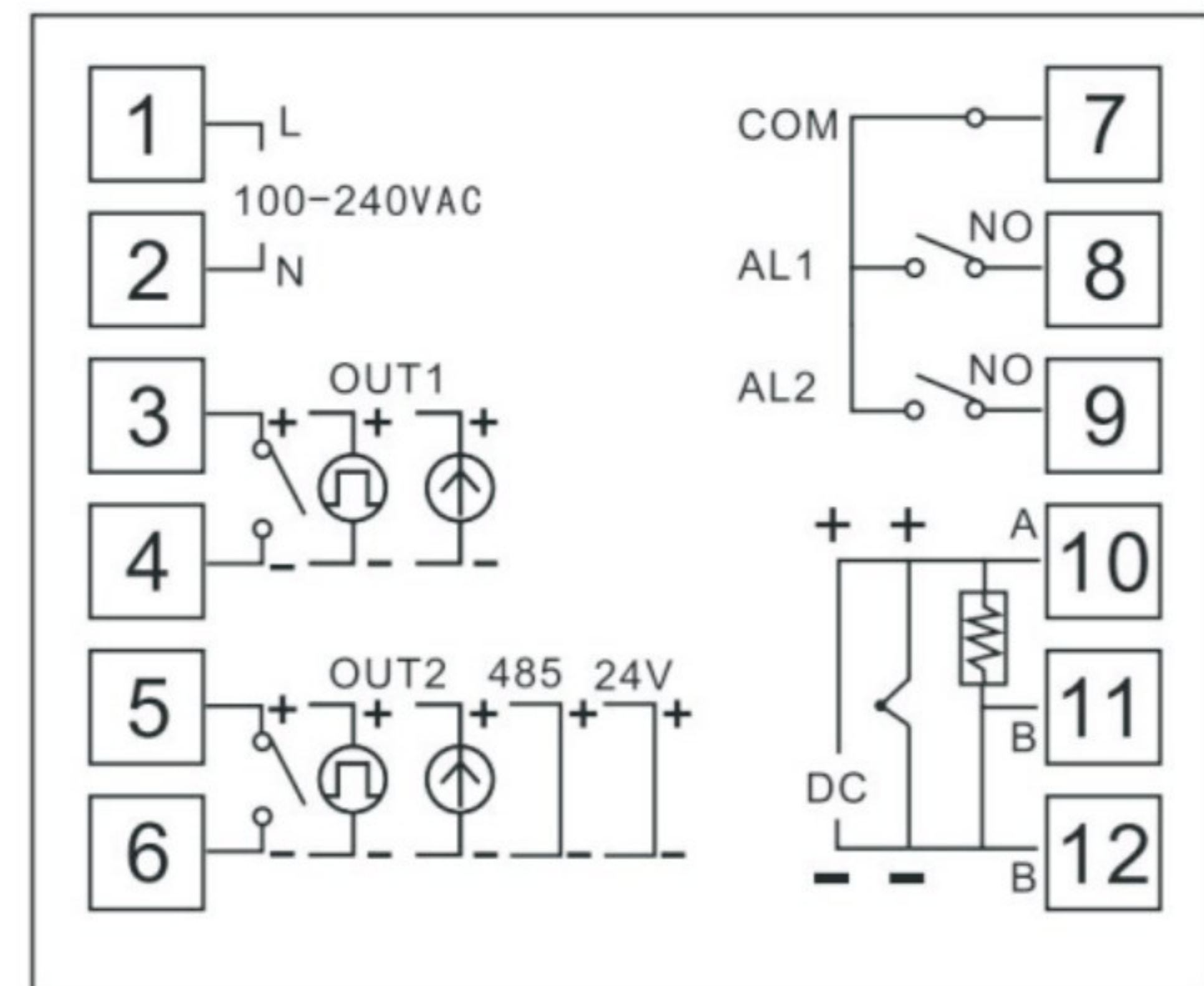

3.Wiring Instructions

⚠ Attention

- Power must be off before wiring, or else, electric shock may occur.
- Do not touch terminal or other electric parts after wired, or else, electric shock may occur.

- (1) Check carefully and ensure wiring is correct according to the terminal arrangement on the temperature controller.
- (2) For thermal couple input, use correct compensation lead that matches the thermal couple.
- (3) For platinum resistance input, each lead resistance should be less than 5ohm, and three leads should have the same resistance.
- (4) Input signal should not be connected to the heavy current within the same lead or cable.
- (5) Shielded cable (single-point grounding) is effective in resisting static induction noise.
- (6) Cross sectional area of insulator cable should be larger than or equal to 1mm, for power supplying.

8. Key operation instructions

1. Basic Operation

Step One: measure the types of the input signal

- Press set key and ◀ to enter level 2.
- In the INP option, press the ◀, the SV monitor will flash.
- Press ▲ or ▼ key to choose the input signal(refer to the signal input diagram)
- Press SET key to confirm amend.
- Press SET key and ◀ key to return to LEVEL0.

Step Two: Alarm mode setting Ad1(The same step applies to Ad2)

- Press SET key and ◀ at the same time to enter LEVEL 2.
- Press SET key for a few times until Ad1 option appears, and then press ◀, SV monitor will flash.
- When the setting is done, press SET to confirm.
- Press SET key to confirm amend.
- Press SET key and ◀ key to return to LEVEL0.

Step Three: Alarm Value Setting AL1(The same applies to AL2)

- Press SET key for a few times until AL1 option appears, and then press ◀ key, SV monitor will flash.
- Press ▲ or ▼ key to choose the input signal(refer to the signal input diagram)
- When the setting is done, press SET to confirm.
- Press SET for a few times to return to LEVEL0

Notice: In the alarm mode 0,1,4,5,6; AL1 and AL2 value is the SV variation value. In mode 2, 3,7, AL1 and AL2 value is the resolution of the temperature alarm value. There is no rules in mode 8. In mode 10, AL1 and AL2 value is time, and the unit is minute. AL1 and AL2 can choose the alarm mode 11, to act as the ending alarm for any group. In mode 12, 13, no value is needed to act as the starting or ending alarm.

Step Four: Setting the program process curve and running.

- Under the

PV
SV

 window
- Press SET key to set the STA value.
- According to the technique requirement, pre-set a few steps and groups program process curve, and then press SET key for a few times to enter the C01 setting layer. Press ◀ key, and use ▲ and ▼ keys to set up the ultimate temperature value of the first group first step. Then press SET key to enter

T01

 setting layer, and apply the same operation to set the ultimate time(set minute as the unit). Set the maximum value

OU01

 for the first group as (0-100.0) and so forth, to complete the multiple groups of the first step.
- Pay attention to this, when the value of the group and step has been set, the CX, TX, OUX of the next group should be set as "0", which is the secluded group and symbol of the previous and next groups.
- The maximum groups for this controller is 60, so groups and steps can only be set within 60 groups.
- | |
|-----|
| CAL |
|-----|

 Menu is the signal of the first sement of all the running group. For example, in the third pre-set technique steps, if we need to set the 15 group as the first group, choose the third group

CAL

=15 to initiate. In order to improve the accuracy of the heating group, Variable gain KP=(0.1~1.0) and the setting variation value EK=1.0-5.0 is added to be set.
- If we need to initiate the program from 0, pls set the

STA

 value to be "1". If PV initiation is need, pls set the STA value to be 2
There is two ways to end the program in the

END

 setting layer.
- SN setting layer can be chose during the program running procedure. It can change the group number in the running group, so as to skip forth or back of the groups. When choosing ST setting layer, the timing of the running group can be amended manually.
- The program can be initiate, only when the parameter is under the running status and the RUN value is set to "1". To end the program, press SET key and AM key at the same time.
- To stop or continue the program, please press ▲ key.
- To make sure the constant temperature's time is constant during the heating process, you can choose WB setting layer to add the waiting temperature zone(0°C~10°C), default when WB=0.
- The time and way to set running status using ON/OFF key.
 - Press ON/OFF key for 3-4 seconds, program initiates. Then press the same key for 3-4 seconds, program ends.
 - When the program is running, press the key for 1-2 seconds, program stops, press the same key again, program continues to work.

Step 5: 1. Parameters Auto-tuning(AT)

- If the filed condition is available, please try to run Auto-tuning(AT)to adjust the parameter values. Try to use the same working load as the controller to run the AT.
- To adjust the thermotechnical values, the AT process would not fail at most times.
- The maximum value of the process curve is under 80% of the parameter checking range.
- Here is the best condition to run the AT: the program is not initiating(fix value control STA=0), SV=0.3 and the process curve is in the maximum value.